





# Design Mould

STAMPI PER DECORARE TORTE A RILIEVO  
Moulds for decorating embossed cakes  
Moules pour décorer les gâteaux en relief

Formen, um Torten mit Relief zu verzieren  
Moldes para decorar tartas en relieve  
Moldes para decorar bolos com relevos

ROMBI

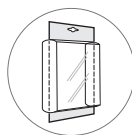

Cod: **30706**  
cm: L19,2xH11,5  
pz: 1 Blister  
mat: SL

DAMASCATO

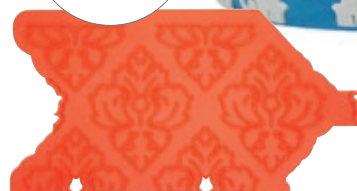

Cod: **30708**  
cm: L21,5xH11,3  
pz: 1 Blister  
mat: SL

RETE



Cod: **30709**  
cm: L19,5xH11  
pz: 1 Blister  
mat: SL

ARABESQUE



Cod: **30710**  
cm: L19,3xH11,5  
pz: 1 Blister  
mat: SL

MERLETTO



Cod: **30711**  
cm: L19,3xH11,5  
pz: 1 Blister  
mat: SL

FIORI



Cod: **30721**  
cm: L18xH11  
pz: 1 Blister  
mat: SL

Da utilizzare esclusivamente con Pasta di Zucchero **POP**

To be used only with **POP** fondant

A utiliser exclusivement avec les pâtes à sucre **POP**

Nur mit dem **POP** Fondant zu verwenden

Utilizar sólo con los Fondant **POP**

Debe utilizar-se unicamente com pastas de açúcar **POP**

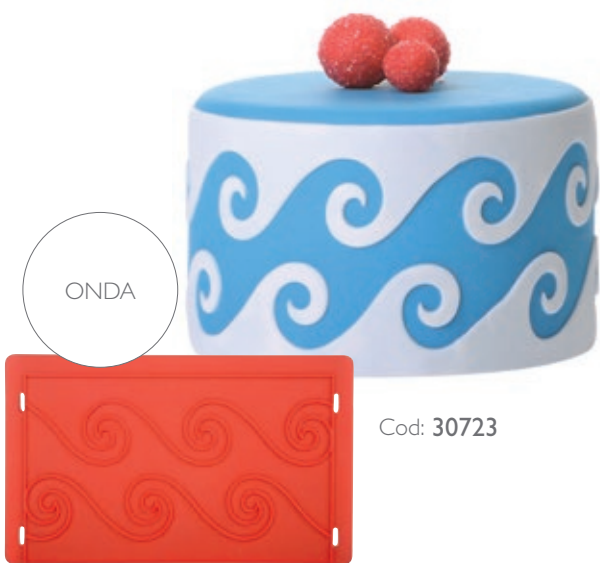



# STAMPI IN SILICONE

Silicone Moulds  
Moules en silicone  
Silikonformen

Moldes de silicona  
Moldes de silicone

Ideali per cioccolato e  
pasta di zucchero

Ideal for chocolate  
and fondant

Idéals pour le choco-  
lat et la pâte à sucre

Ideal für Schokolade  
und Zuckermasse

Ideales para chocola-  
te y fondant

Ideias para chocolate  
e pasta de açúcar

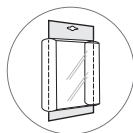

Cod: **30329**  
cm: Ø6,2xP1  
pz: 1 Blister  
mat: SL

ISTRUZIONI  
HOW  
TO USE

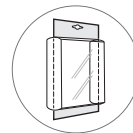

Cod: **30331**  
cm: L7,2xH7,2xP1,5  
pz: 1 Blister  
mat: SL

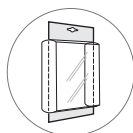

Cod: **30333**  
cm: L8,2xH12,3xP1,7  
pz: 1 Blister  
mat: SL

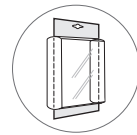

Cod: **30332**  
 cm: L9,2xH13xP2  
 pz: 1 Blister  
 mat: SL

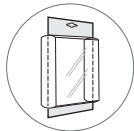

Cod: **30327**  
 cm: L6xH9xP1,8  
 pz: 1 Blister  
 mat: SL

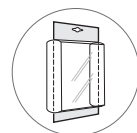

Cod: **30330**  
 cm: L8,5xH8,5xP1,8  
 pz: 1 Blister  
 mat: SL



# STAMPI IN SILICONE

Silicone Moulds  
Moules en silicone  
Silikonformen

Moldes de silicona  
Moldes de silicone

Ideali per cioccolato e  
pasta di zucchero

Ideal for chocolate  
and fondant

Idéals pour le choco-  
lat et la pâte à sucre

Ideal für Schokolade  
und Zuckermasse

Ideales para chocola-  
te y fondant

Ideias para chocolate  
e pasta de açúcar

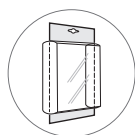
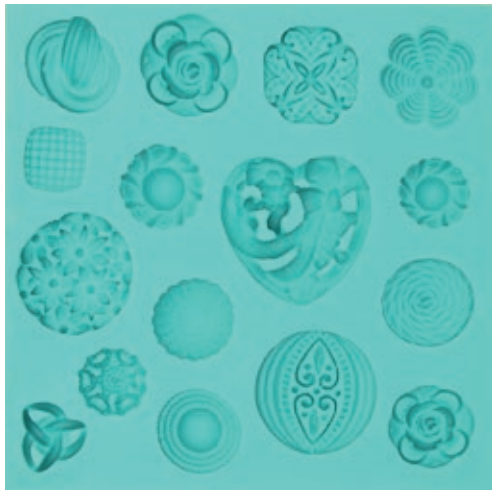

Cod: **30326**  
cm: L10,5xH10,5xP1,2  
pz: 1 Blister  
mat: SL

ISTRUZIONI  
HOW  
TO USE

Ideali per pasta di  
zucchero

Ideal for fondant

Idéals pour la pâte à  
sucre

Ideal für Zuckermasse

Ideales para pasta de  
azúcar

Ideias para pasta de  
açúcar

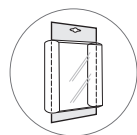
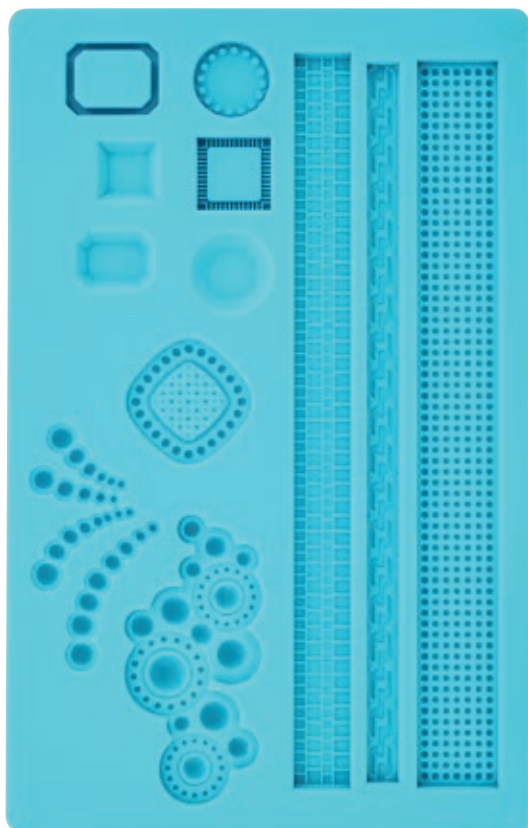

Cod: **30375**  
cm: L20xH12,5xP1  
pz: 1 Blister  
mat: SL

Cod: **30376**

# STAMPI IN ACCIAIO

Stainless steel cutters

Coupe-pâte en acier

Ausstecher aus rostfreiem Stahl

Moldes de acero inoxidable

Moldes de aço inoxidável

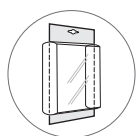

Cod: **30818P**  
cm: L4xH5,8xP1,6  
pz: 1 Blister  
mat: MT

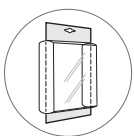
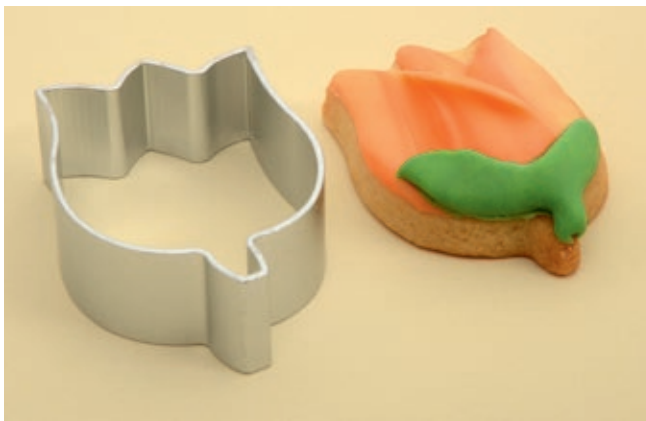

Cod: **30819P**  
cm: L3,7xH5,2xP1,7  
pz: 1 Blister  
mat: MT

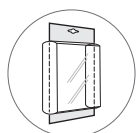

Cod: **30820P**  
cm: L7xH4xP1,7  
pz: 1 Blister  
mat: MT

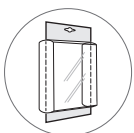

Cod: **30821P**  
cm: L4,2xH6xP3  
pz: 1 Blister  
mat: MT

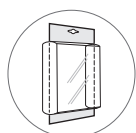

Cod: **30824P**  
cm: L5,2xH6xP1,7  
pz: 1 Blister  
mat: MT



Cod: **30823P**  
cm: Ø4,5xP1,7  
pz: 1 Blister  
mat: MT



# STAMPI IN ACCIAIO

Stainless steel cutters  
Coupe-pâte en acier  
Ausstecher aus rostfreiem Stahl

Moldes de acero inoxidable  
Moldes de aço inoxidável



Cod: 30822P  
cm: L6,3xH2,4xP1,7  
pz: 1 Blister  
mat: MT

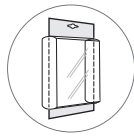

180°



Cod: 30308  
●●● A  
■ ■ ■ 9  
cm: H3,5  
pz: 1 Blister(9pz)  
mat: MT



Cod: 30307  
●●● A  
■ ■ ■ 26  
cm: H2,5  
pz: 1 Blister(26pz)  
mat: MT





# TAGLIAPASTA

Cookie cutter  
Coupe-pâte  
Ausstecher

Cortapastas  
Cortador de pasta



QUADRATO  
Cod: **30738**  
cm: L6,6  
pz: 1 Blister  
mat: MT

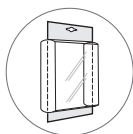

GEOMETRICO  
Cod: **30888**  
cm: L5,6xH8,6  
pz: 1 Blister  
mat: MT



TOY CAR  
Cod: **30890**  
cm: L8,6xH5,3  
pz: 1 Blister  
mat: MT



BEAUTY QUEEN  
Cod: **30889**  
cm: L7,1xH8,3  
pz: 1 Blister  
mat: MT



DECORARE IN  
LABORATORIO  
Decorating in the lab



# TAGLIAPASTA

Cookie cutter  
Coupe-pâte  
Ausstecher

Cortapastas  
Cortador de pasta



L5,2xH7cm



L6,5xH6,4cm



L6,5xH7cm

NASCITA  
Cod: 30488

●●● A  
■ ■ ■ 3

pz: 1 Blister (3pz)  
mat: MT

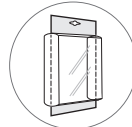

LOVE  
Cod: 30486  
cm: L6,7xH6,5  
pz: 1 Blister  
mat: MT

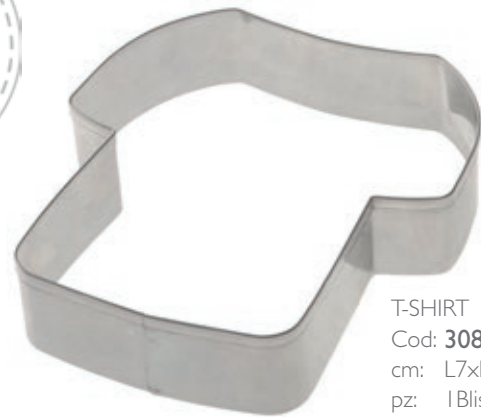

T-SHIRT  
Cod: 30814  
cm: L7xH7,3  
pz: 1 Blister  
mat: MT



L5,5xH6,8cm



L6xH7cm

HAPPY EASTER  
Cod: 30487

●●● A  
■ ■ ■ 2

pz: 1 Blister (2pz)  
mat: MT

# GLI STAMPI ROSSI

The red moulds  
Les moules rouges  
Rote Formen

Los moldes rojos  
Os moldes vermelhos



## Crystal Decor

ISTRUZIONI  
HOW  
TO USE



Ideali per creare  
pizzi con Sweet Lace  
Express e Isomalto

Ideal for creating  
lace with Sweet Lace  
Express and Isomalt

Parfaits pour réaliser  
des dentelles avec  
Sweet Lace Express  
et Isomalt

Ideal zur Gestaltung  
von Spitzen mit Swe-  
et Lace Express und  
Isomalt

Ideales para crear en-  
cajes con Sweet Lace  
Express e Isomalt

Ideais para criar ren-  
das com Sweet Lace  
Express e Isomalte



HAPPY  
EASTER



Cod: 31230  
cm: L39xH7  
pz: 1 Blister  
mat: SL

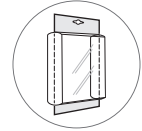



# STAMPI IN SILICONE

Silicone Moulds  
Moules en silicone  
Silikonformen

Moldes de silicona  
Moldes de silicone

Ideali per cioccolato e  
pasta di zucchero

Ideal for chocolate  
and fondant

Idéals pour le choco-  
lat et la pâte à sucre

Ideal für Schokolade  
und Zuckermasse

Ideales para chocola-  
te y fondant

Ideias para chocolate  
e pasta de açúcar

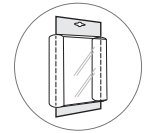

Cod: **30338**  
cm: L9,5xH6xP1,6  
pz: 1 Blister  
mat: SL

ISTRUZIONI  
HOW  
TO USE

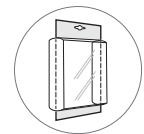

Cod: **30337**  
cm: L16xH9xP1,3  
pz: 1 Blister  
mat: SL

# STAMPO AD ESPULSIONE

Ejector cutter | Moule de découpe à expulsion | Ausstecher mit Auswerfer | Molde a expulsión | molde de expulsão

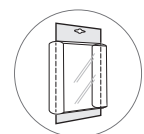

Cod: **30344**  
● ● ● A  
■ ■ ■ 4  
cm: L3/5xH4/5  
pz: 1 Blister(4pz)  
mat: PL

# MATTARELLO CON GUIDE

Rolling pin with guides

Rodillo con guías

Rouleau à pâtisserie avec guides

Rolo de polietileno com guias

Teigrolle mit Ringen



Cod: **30288**

cm: Ø2,5xL23

pz: 1 Blister

mat: PL



GUIDA VIOLA

Violet guide  
Guide violet  
Violetter Ring  
Guía violeta  
Guia violeta

H3mm

GUIDA ROSA

Pink guide  
Guide rose  
Rosa Ring  
Guía rosa  
Guia rosa

H2mm

# MATTARELLO ANTIADERENTE IN POLIETILENE

Non-stick polythene (PE) rolling pin

Rouleau à pâtisserie anti-adhérent en polyéthylène

Anti-Haft Teigrolle aus Polyethylen (PE)

Rodillo de polietileno, antiaderente

Rolo de polietileno, antiaderente



Cod: **31235**

cm: Ø4,2xL50

pz: 1 Blister

mat: PL



# MATTARELLI

Rolling pins

Rodillos

Rouleaux à pâtisserie

Rolos

Teigrollen

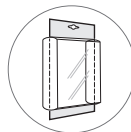

Cod: **30219**

cm: Ø2,5xL29

pz: 1 Blister

mat: PL

GIGLIO | Lily | Fleur de lys | Lilie | Lirio | Lírio



Cod: **30220**

ROSONE | Rosette | Rosette | Rosette | Florón | Roseta



Cod: **30271**

CUORI | Hearts | Cœurs | Herzen | Corazones | Corações





# ATTREZZI PER PASTA MODELLABILE

Modelling paste tool set  
Outils pour pâte modelable  
Werkzeuge für modellierbare Masse

Utensilios para pasta moldeable  
Utensílios para massa moldável

Prodotto da utilizzare come attrezzo da modelling e non come attrezzatura da cucina

Product to be used only as a modelling tool - not for use as kitchen utensil

Produit à utiliser pour "modelling" et non comme ustensile de cuisine

Produkt zum Modellieren aber nicht zum Kochen

Producto a utilizar como utillaje para moldeo y no como herramienta de cocina

Produto a ser utilizado como utensílio de modelagem e não como utensílio de cozinha

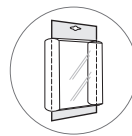
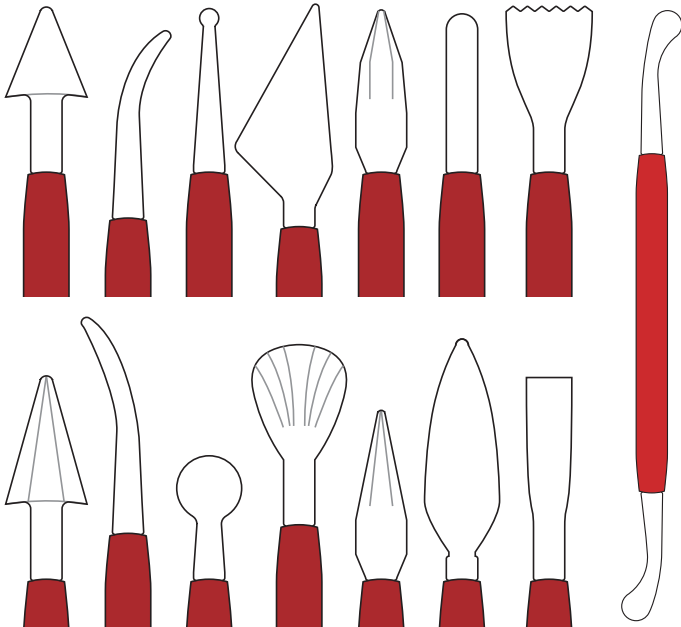

Cod: **30264**  
● ● ● A  
■ ■ ■ 8  
cm: H16,5  
pz: 1Blister(8pz)  
mat: PL

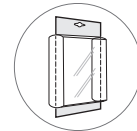
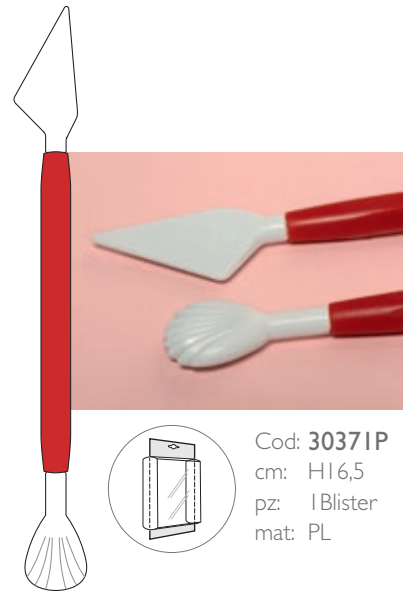

Cod: **30371P**  
cm: H16,5  
pz: 1Blister  
mat: PL

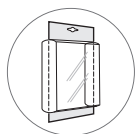
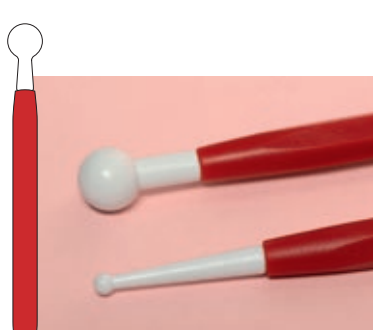

Cod: **30372P**  
cm: H14  
pz: 1Blister  
mat: PL

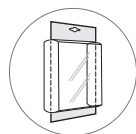

Cod: **30397P**  
cm: H16,5  
pz: 1Blister  
mat: PL

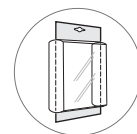
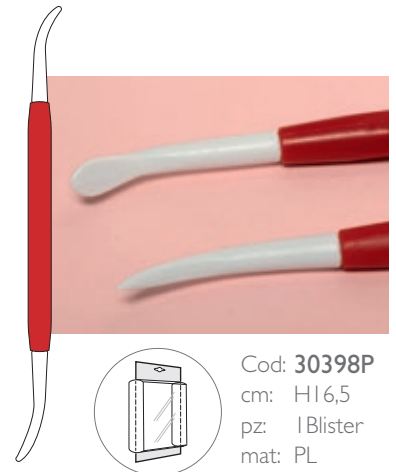

Cod: **30398P**  
cm: H16,5  
pz: 1Blister  
mat: PL

## CUTTER A ROTELLE

Wheel cutter | Roulette à pâtisserie | Rollmesser | Cortador a rodillo | Cortador com rodelas

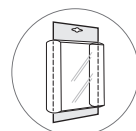

Cod: **30399P**  
cm: H16,5  
pz: 1Blister  
mat: PL

# STRUMENTI PER TAGLIARE E INCIDERE

Fondant Cutters & Embossers  
Outils pour couper et graver  
Werkzeug zum Schneiden und Einprägen

Utensilios para cortar e incidir  
Utensílios para marcar e cortar

Rotelle interscam-  
biabili

Interchangeable  
wheels

Roulettes interchan-  
geables

Austauschbare  
Rädchen

Rodillos intercam-  
biables

Rodelas intercam-  
biáveis

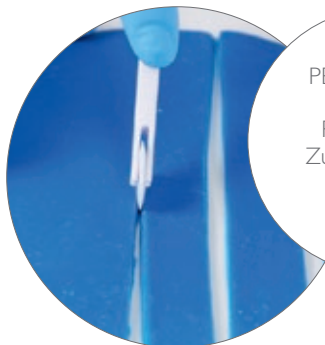

PER TAGLIARE  
For cutting  
Pour couper  
Zum Schneiden  
Para cortar  
Para cortar



PER IMPRIMERE  
A RILIEVO  
For embossing  
Pour impression en relief  
Für Reliefprägung  
Para imprimir en relieve  
Para moldar  
em relevo

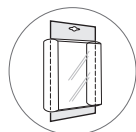

Cod: 30292  
pz: 1Blister(4pz)  
mat: PL

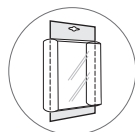

Cod: 30341  
pz: 1Blister(4pz)  
mat: PL

DECORARE IN  
LABORATORIO  
Decorating in the lab

# TIMBRATAGLIA

Fondant decorative punch set  
Kit emporte pièces pour pâte à sucre  
Dekoratives Fondant Stanz Set

Sello cortapastas  
Selo corta-pasta

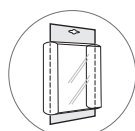

Cod: 30269  
pz: 1Blister(9pz)  
mat: PL



# SPATOLA PER MODELLARE

Modelling spatula  
Spatule pour modeler  
Großer Schaber

Espátula para moldear  
Espátulas para modelar



Cod: **30263**  
cm: L8xH14,5  
pz: 1 Blister  
mat: PL

# PINZE PER INCISIONI

Crimper  
Pincés pour incisions  
Kneifer

Pinzas para incisiones  
Pinças para cortes

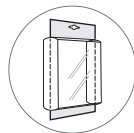

Cod: **30203**  
● ● ● A  
■ ■ ■ 2  
cm: L1,5xH8,5  
pz: 1 Blister(2pz)  
mat: MT



Cod: **30204**



Cod: **30373**



Cod: **30374**



# BECCUCCI PER SAC À POCHE

Piping nozzles  
Douilles pour sac à poche  
Spritzbeutel-Tüllen

Boquillas para mangas  
Boquilhas para sacos de pasteiro



SENZA GIUNTURE  
Without joints  
Sans joints  
Ohne Fugen  
Sin juntas  
Sem junções

BECCUCCI IN ACCIAIO  
Steel piping nozzles  
Douilles en acier  
Stahl-tüllen  
Boquillas de acero  
Boquilhas em aço

Cod: 30838  
pz: 10Blister  
mat: MT



Cod: 30832



Cod: 30833



Cod: 30834



Cod: 30835



Cod: 30836



Cod: 30831 mm: Ø4



Cod: 30830 mm: Ø3



Cod: 30829 mm: Ø2



Cod: 30828 mm: Ø1

BECCUCCI IN ALLUMINIO  
Aluminum piping nozzles  
Douilles en aluminium  
Aluminiumtüllen  
Boquillas de aluminio  
Boquilhas em alumínio



Cod: 30265

●●● A

■ ■ ■ 6

pz: 1Blister(6pz)

mat: MT

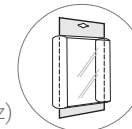



# Grippy Poche

Il sac à poche ad alta aderenza

The perfect grip sac à poche

Le sac à poche haute adhérence

Der Spritzbeutel anti-rutsch

La manga pastelera de alta adherencia

O saco de confeitar de elevada aderência



RUVIDO ALL'ESTERNO,  
LISCIO ALL'INTERNO  
Grippy outside, smooth inside  
Rugueux à l'extérieur; lisse à l'intérieur  
Außen rau, innen glatt  
Áspero en el exterior; liso en el interior  
Lado externo áspero e lado interno liso

NON SCIVOLA  
Won't slip | Ne glisse pas | Rutschfest  
No desliza | Não desliza

SUPER RESISTENTE  
Super resistant | Super résistant | Super reißfest  
Super resistente | Super resistente

UNA SOLA GIUNTURA  
Only one seam Une seule jonction | Nur eine Naht  
Una sola junta | Uma única junção

USA E GETTA  
Disposable | À usage unique | Einwegbeutel  
Desechable | Descartável



LARGE  
Cod: 30301

cm: L53  
pz: 400 (100x4)

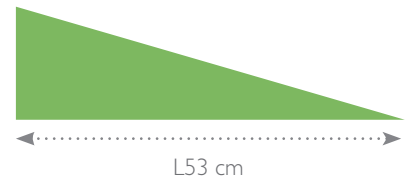

SMALL  
Cod: 30303

cm: L36  
pz: 400 (100x4)

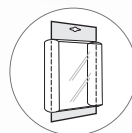
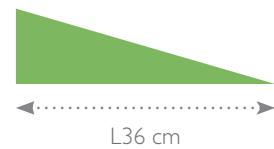

MEDIUM  
Cod: 30266

cm: L41  
pz: 12Blister(20pz)

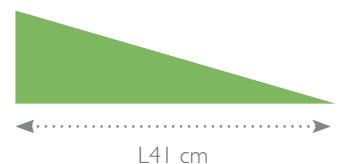

# SOTTOTORTA PROFESSIONALE

Professional cake board  
Support gâteau professionnel  
Professioneller Unter-Kuchenteller

Base para tarta, profesional  
Base para bolo, profissional

YouTube  
Moddecor  
Italiana



100% atto al contatto alimenti	100% foodsafe	100% apte au contact alimentaire	100% geeignet für Kontakt mit Leben- smitteln	100% apto al contac- to con alimentos	100% apto para estar em contacto com alimentos
100% plastificato bianco	100% white plastic coated	100% plastifié blanche	100% mit weißem Plastik überzogen	100% plastificado blanco	100% plastificado branco

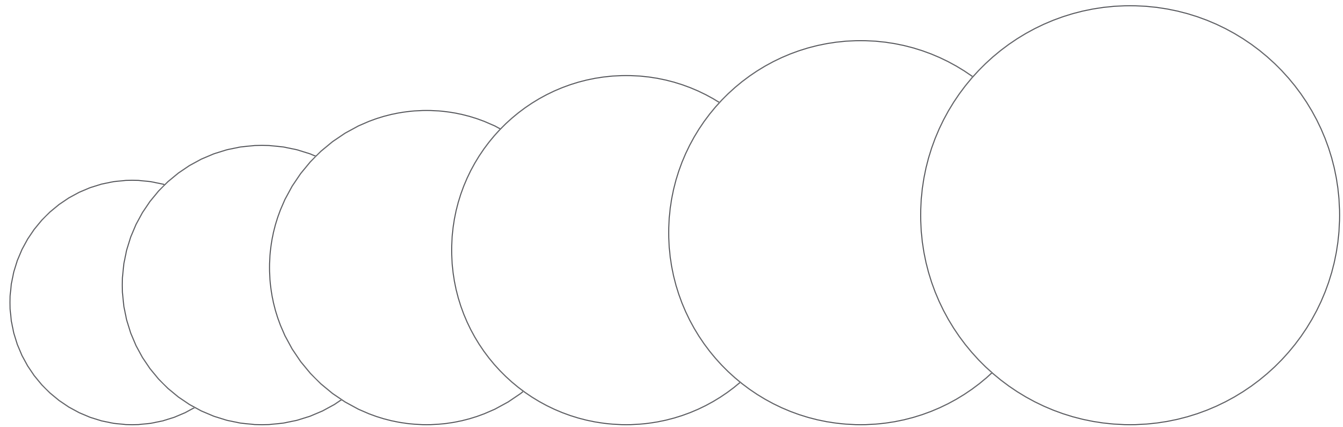

Cod: **13124**  
cm: Ø20

Cod: **13125**  
cm: Ø24

Cod: **13126**  
cm: Ø28

Cod: **13127**  
cm: Ø32

Cod: **13128**  
cm: Ø36

Cod: **13129**  
cm: Ø40xH0,15  
pz: 20  
mat: CT

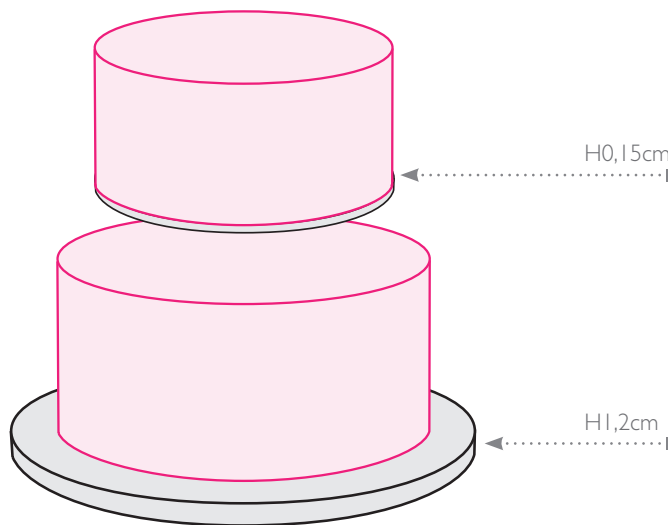

## TUBI IN PLASTICA PER SOSTEGNO LIVELLI TORTE A PIANI

Plastic tubes to use as supports for multi layer cakes  
Tubes en plastique pour support gâteaux à plusieurs étages  
Rohre aus Plastik für mehrstöckige Torten

Tubos de plástico para sostener tartas de varios pisos  
Tubos de plástico para sustentar bolos de vários andares

Possibilità di taglio a misura	Cut to desired height	Possibilité de coupe à la mesure désirée	Passgenaue Schnitte möglich	Posibilidad de corte a medida	Possibilidade de corte à medida
-----------------------------------	-----------------------	---	--------------------------------	----------------------------------	------------------------------------



Cod: **30358**  
cm: Ø1,9xH20  
pz: 50  
mat: PL



# COMPONENTI PER TORTE A PIÙ PIANI

Multi-layer cake components  
Composants pour pièces montées  
Tortenplatten für Stockwerk torten

Componentes para armar tartero de varios pisos  
Componentes para montar suporte de vários andares

Atto al contatto  
alimenti

Foodsafe

Apte au contact  
alimentaire

Geeignet für Kontakt  
mit Lebensmitteln

Apto al contacto con  
alimentos

Apto para estar  
em contacto com  
alimentos

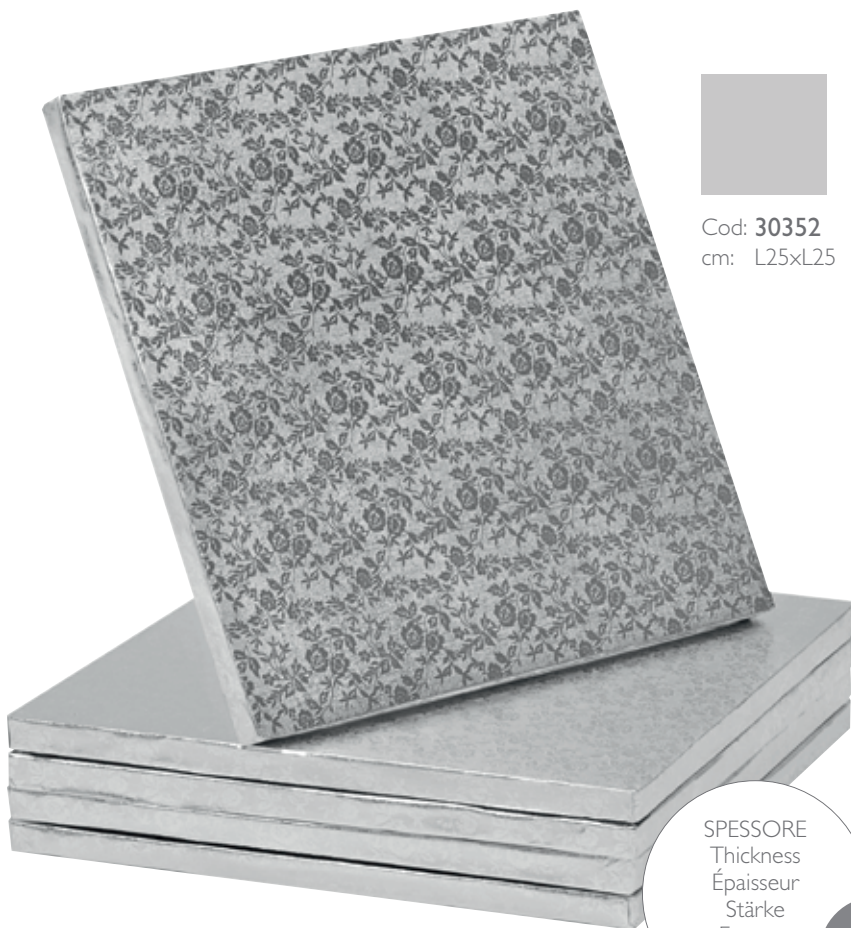

Cod: **30352**  
cm: L25xL25



Cod: **30353**  
cm: L30xL30



Cod: **30354**  
cm: L35xL35



Cod: **30355**  
cm: L40xL40



Cod: **30356**  
cm: L45xL45

Cod: **30357**  
cm: L50xL50  
pz: 5  
mat: CT



SPESSORE  
Thickness  
Épaisseur  
Stärke  
Espesor  
Grossura

1,2cm

## Washi Tape

NASTRO ADESIVO IN CARTA PER BORDI  
Adhesive paper tape for borders  
Ruban adhésif en papier pour bords

Tesafilm aus Papier für Rändern  
Cinta adhesiva de papel para bordes  
Fita adesiva de papel para bordes



Cod: **30899**  
cm: L10m x H1,5cm  
pz: 6



Cod: **30893**

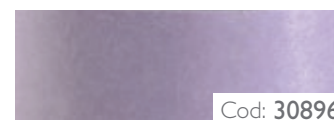

Cod: **30896**

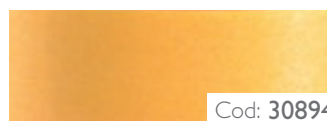

Cod: **30894**

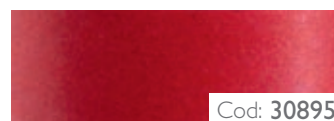

Cod: **30895**

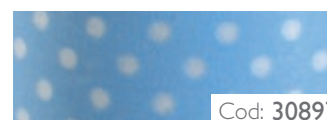

Cod: **30897**

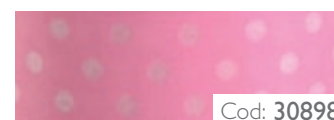

Cod: **30898**



DECORARE IN  
LABORATORIO  
Decorating in the lab

Atto al contatto  
alimenti

Foodsafe

Apte au contact  
alimentaire

Geeignet für Kontakt  
mit Lebensmitteln

Apto al contacto con  
alimentos

Apto para estar  
em contacto com  
alimentos

Plasticato

Plastic coated

Plastifié

Mit Plastik überzogen

Plasticado

Plasticado



Cod: **30466**  
cm: L25xL35



Cod: **30467**  
cm: L30xL40



Cod: **30468**  
cm: L35xL45



Cod: **30469**  
cm: L40xL50



Cod: **30470**  
cm: L45xL55  
pz: 5  
mat: CT

SPESSORE  
Thickness  
Épaisseur  
Stärke  
Espesor  
Grossura

1,2cm

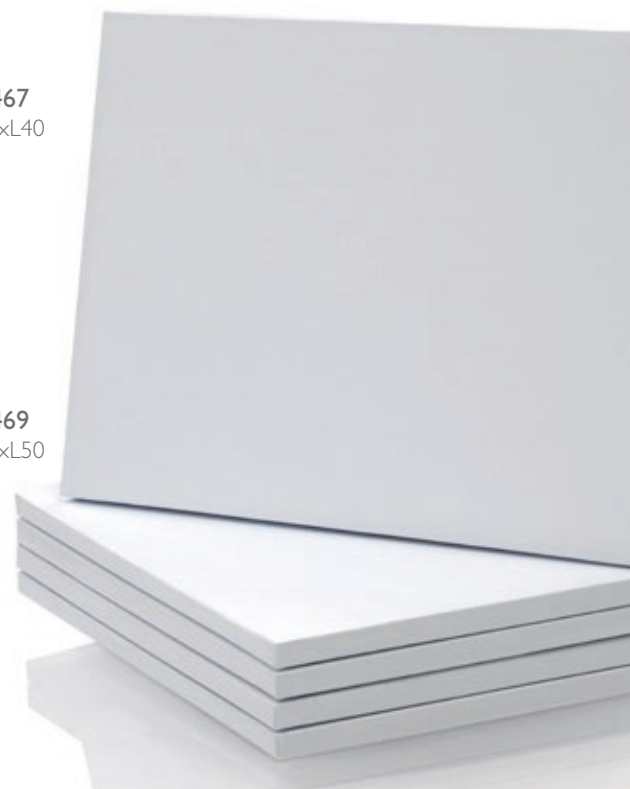



# COMPONENTI PER TORTE A PIÙ PIANI

Multi-layer cake components  
Composants pour pièces montées  
Tortenplatten für Stockwerk torten

Componentes para armar tartero de varios pisos  
Componentes para montar suporte de vários andares



YouTube  
Modacor  
Italiana

Atto al contatto  
alimenti

Foodsafe

Apte au contact  
alimentaire

Geeignet für Kon-  
takt mit Leben-  
smitteln

Apto al contacto  
con alimentos

Apto para estar  
em contacto com  
alimentos



Cod: **30345**  
cm: Ø20



Cod: **30346**  
cm: Ø25



Cod: **30347**  
cm: Ø30



Cod: **30348**  
cm: Ø35

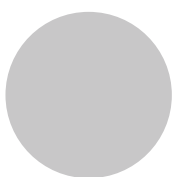

Cod: **30349**  
cm: Ø40

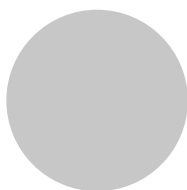

Cod: **30350**  
cm: Ø45

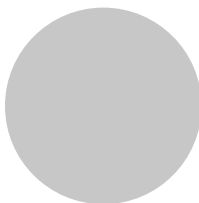

Cod: **30351**  
cm: Ø50  
pz: 5  
mat: CT

Plasticato | Plastic coated

Plastifié | Mit Plastik überzogen

Plastificado | Plastificado

SPESSORE  
Thickness  
Épaisseur  
Stärke  
Espesor  
Grossura

1,2cm



Cod: **30474B**  
cm: Ø30  
pz: 5  
mat: CT



Cod: **30475B**  
cm: Ø35

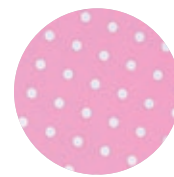

Cod: **30476B**  
cm: Ø40



Cod: **30474C**



Cod: **30475C**

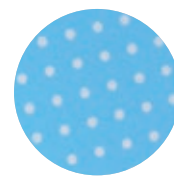

Cod: **30476C**

# CONFEZIONI PER TORTE

Display cake boxes  
Boîtes pour gâteaux  
Verpackungen für Torten

Cajas para tartas  
Caixas para bolos

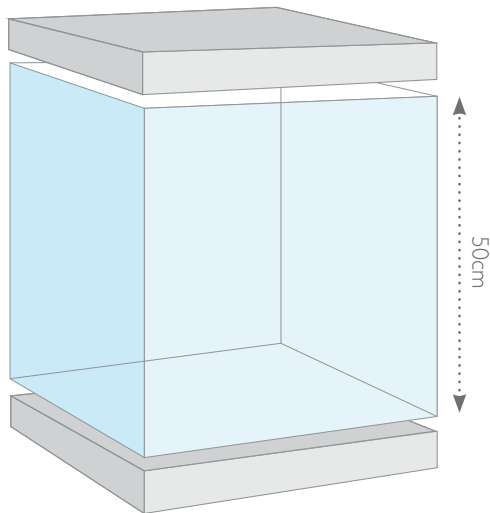

Cod: **30801**  
cm: L50xH54xP50  
pz: 5Kit(3pz)  
mat: CT/PL



DECORARE IN  
LABORATORIO  
Decorating in the lab

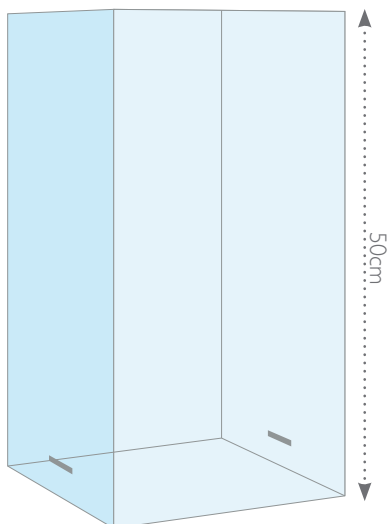

Cod: **30806**  
cm: L30xH50xP30  
pz: 2  
mat: PL

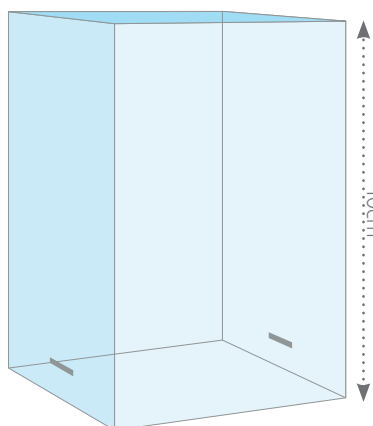

Cod: **30805**  
cm: L30xH40xP30  
pz: 2  
mat: PL

Base e relativo  
coperchio  
sono da ven-  
dere abbinati

Base and  
related cover  
are to be sold  
together

Base et cou-  
vercle associé  
sont vendus  
ensemble

Basis und ent-  
sprechender  
Deckel müs-  
sen zusam-  
men ver-  
kauft wer-  
den

La base y la  
tapa se ven-  
den juntas

A base e a  
tampa se ven-  
dem juntas

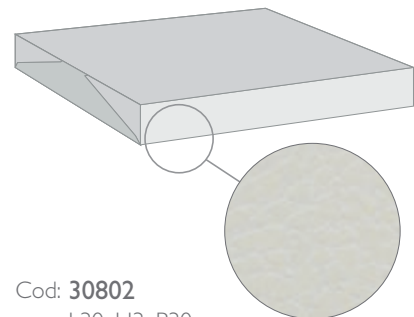

Cod: **30802**  
cm: L30xH3xP30  
pz: 10  
mat: CT

Scegli l'altezza del co-  
perchio da abbinare  
alla base

Choose cover height  
to match the base

Choisissez la hauteur  
du couvercle à asso-  
cier avec la base

Wählen Sie die Höhe  
des Deckels, der mit  
dem Boden kombi-  
niert werden soll

Elija la altura de la  
tapa para asociar a  
la base

Escolhe a altura da  
tampa para associar  
à base



## PIATTO GIREVOLE ANTISCIVOLO

Non-slip revolving dish  
Plateau tournant antiglisse  
Antirutschplatte drehbar

Plato giratorio anti-deslizamiento  
Prato giratório anti-deslizante



Cod: **30368**  
cm: Ø27xH7,5  
pz: 1  
mat: PL



INCLINABILE  
Tilting  
Inclinable  
Kippbar  
Inclinable  
Inclinável



Cod: **30369**  
cm: Ø23xH14,5  
pz: 1  
mat: PL

## ALZATE PER MUFFIN

Muffin stands  
Présentoirs pour muffin  
Tortenständer für Muffins

Bandejas para muffin  
Bandejas para muffin

Cartone resistente  
finemente rivestito

Finely coated strong  
cardboard

Carton résistant avec  
revêtement élégant

Robuster Karton mit  
feinem Überzug

Cartón resistente  
finamente forrado

Cartão com revestimento  
fino e resistente



Cod: **30381**  
cm: L35/30/20xH33  
pz: 1  
mat: CT



Cod: **30383**



# CONFEZIONI PER MUFFIN E CUPCAKE

Packs for muffins and cupcakes  
Emballages pour muffin et pour cupcakes  
Verpackung für Muffins und Cupcakes

Confecciones para madalenas y cupcake  
Confeções para muffin e bolos de forminha

Base utilizzabile con muffin classico e con mini muffin

Base for classic and mini-muffins

Base utilisable avec muffin classique et avec mini muffin

Basis für klassische Muffins und Mini-Muffins

Base utilisable con madalena clásica y con mini madalena

Base utilizável com muffins clássicos ou com mini muffins



12pz  
Ø4,5cm

180°



6pz  
Ø6,5cm



Cod: 30807  
cm: L24,5xH7,5xP16,5  
pz: 10  
mat: CT



Cod: 30808

DECORARE IN  
LABORATORIO  
Decorating in the lab





# DECORAZIONI PER MUFFIN

Muffin decorations  
Décorations pour muffin  
Muffin Dekorationen

Decoraciones para muffin  
Decorações para muffin

PRODOTTI NON  
DA FORNO  
Products NOT for baking  
Produits NON  
utilisables au four  
NICHT backofenfest  
NO aptos para horno  
Productos NÃO aptos  
para forno



180°C

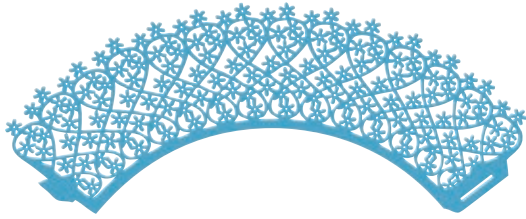

Cod: 30388C  
cm: Ø5,5/8xH5,5  
pz: 12  
mat: CT

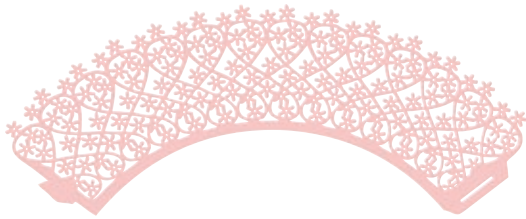

Cod: 30388B



Cod: 30389I



Cod: 30390Z



Cod: 30389H



# SET PER CUPCAKE

Set for cupcakes  
Set pour cupcake  
Cupcake-Set

Set para cupcake  
Kit para Cupcake

MONOUSO  
Disposable  
Jetable  
Einweg  
Desechable  
Descartável

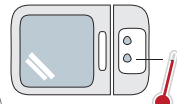

180°C



DECORARE IN  
LABORATORIO  
Decorating in the lab

I set = I teglia per  
cupcake

I set = I pan for  
cupcakes

I set = I plaque à  
cupcakes

I Set = I Form für  
Cupcakes

I juego = I molde  
para cupcake

I kit = I forma para  
cupcake



Cod: **30387**  
pz: 1Set(48pz)  
mat: CT/PL

24pz  
Ø8xH3,5cm

24pz  
H8cm



# SET PER CUPCAKE

Set for cupcakes  
Set pour cupcake  
Cupcake-Set

Set para cupcake  
Kit para Cupcake

MONOUSO  
Disposable  
Jetable  
Einweg  
Desechable  
Descartável

180°C



24pz  
Ø8xH3,5cm

24pz  
H8cm

Cod: 30384  
pz: 1Set(48pz)  
mat: CT/PL



Cod: 30385



Cod: 30386



# PIROTTINI IN CARTA DA FORNO

Baking Paper Cups  
Caissettes en papier cuisson  
Cupcake-Förmchen aus Backpapier

Cápsulas de papel de forno  
Formas pequenas em papel para forno

MONOUSO  
Disposable  
Jetable  
Einweg  
Desechable  
Descartável

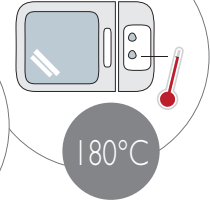

SELF  
STANDING

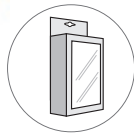

Cod: **13130B**  
cm: Ø7xH4  
pz: 5Set(12pz)  
mat: CT



Cod: **13130E**



Cod: **13130D**



Cod: **13130C**



Cod: **13130L**

DECORARE IN  
LABORATORIO  
Decorating in the lab

Carta da forno resis-  
tente ai grassi

Greaseproof baking  
paper

Papier cuisson résis-  
tant à la graisse

Fettfestes Backpapier

Papel para forno  
resistente a la grasa

Papel para forno  
resistente à gordura

In forno senza stam-  
po da cottura!

In the oven without a  
baking pan!

Au four sans moule  
de cuisson!

Ohne Backform in  
den Ofen!

¡En horno sin molde  
de cocción!

No forno sem forma  
para cocção

# TEGLIA PER MUFFIN IN CARTA DA FORNO

Baking paper muffin pan  
Plaque à muffin en papier cuisson  
Muffinform aus Backpapier

Bandeja, de papel de forno, para muffin  
Forma para muffin em papel para forno

Cod: **13119**

●●●A

■ ■ ■ 2

cm: L25xH3,5xP17

pz: 8

mat: CT



Carta da forno resis-  
tente ai grassi

Greaseproof baking  
paper

Papier cuisson résis-  
tant à la graisse

Fettfestes Backpapier

Papel para forno  
resistente a la grasa

Papel para forno  
resistente à gordura



## PIROTTINI IN CIALDA

Edible wafer cupcake liners  
Coupelles  
Cupcake-Förmchen

Pirotines  
Forminhas

IDEALI PER COTTURA | Ideal for baking

| Idéals pour la cuisson

Ideal zum Backen

| Ideales para cocción

| Ideais para forno



Cod: **25623**  
cm: Ø7,5xH3  
pz: 250  
mat: BS

MONOUSO  
Disposable  
Jetable  
Einweg  
Desechable  
Descartável

220°C

IDEALI PER GELATO  
E SEMIFREDDI

Ideal for ice cream and  
frozen desserts

| Idéals pour la glace et  
les entremets

Ideal für Eis oder Halb-  
gefrorenes

Ideales para helado y  
semifríos

Ideais para gelados e  
semi frios

## STAMPI DA COTTURA PER TORTE

Baking paper moulds for cakes | Moules de cuisson pour gâteaux | Backformen für Kuchen  
Moldes para cocción de tartas | Formas para o forno

Carta da for-  
no resistente  
ai grassi

Greaseproof  
baking paper

Papier cuisson  
résistant à la  
graisse

Fettfestes  
Backpapier

Papel para  
horno resi-  
stente a la  
grasa

Papel para for-  
no resistente à  
gordura

Carta ondu-  
lata in pura  
cellulosa

Pure cellulose  
corrugated  
paper

Papier ondulé  
en pure cel-  
lulose

Wellenpapier  
aus reiner  
Zellulose

Papel ondu-  
lado en celulosa  
pura

Papel on-  
dulado em  
celulose pura

MONOUSO  
Disposable  
Jetable  
Einweg  
Desechable  
Descartável

180°C

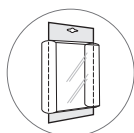

Cod: **13132**  
cm: L13,5xH3,5xP13  
pz: 8Set(2pz)  
mat: CT

Superficie forata  
per garantire una  
cottura uniforme

| Perforated surface  
to guarantee even  
cooking

| Surface perforée  
pour assurer une  
cuisson uniforme

Perforierte Ober-  
fläche, um glei-  
chmäßiges Garen  
gewährzuleisten

| Superficie perfora-  
da para garanti-  
zar una cocción  
uniforme

| Superfície perfu-  
rada para garantir  
uma cozedura  
uniforme

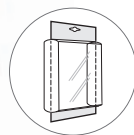

Cod: **19187**  
cm: L22xH4,5xP15  
pz: 8Set(2pz)  
mat: CT



# PRODOTTI PER L'HOBBISTICA

Hobby products  
Produits pour le loisir  
Produkte für Hobbybäcker

Productos para hobbies  
Produtos para hobbies

## POLISTIROLI

Polystyrene | Polystyrène | Polystyrol | Poliestirenos | Poliestirenos



Cod: **30452**  
cm: Ø20  
pz: 8

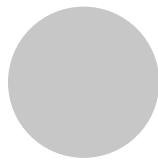

Cod: **30453**  
cm: Ø25  
pz: 8

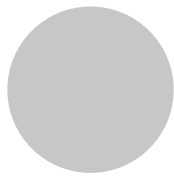

Cod: **30454**  
cm: Ø30  
pz: 2

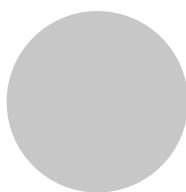

Cod: **30455**  
cm: Ø35  
pz: 2

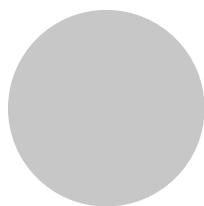

Cod: **30456**  
cm: Ø40  
pz: 2

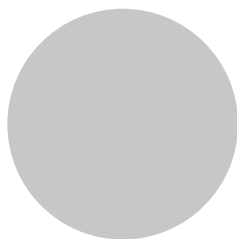

Cod: **30457**  
cm: Ø45  
pz: 2

SPESSORE  
Thickness  
Épaisseur  
Stärke  
Espesor  
Grossura

5cm



DECORARE IN  
LABORATORIO  
Decorating in the lab

Confezionati in  
cartoni

Packed in boxes

Conditionnés en  
cartons

In Kartons verpackt

Embalados en car-  
tones

Embalados em  
cartões

## SPATOLE IN METALLO

Metal spatulas | Spatules métalliques | Metallspatel  
Espátulas de metal | Espátulas de metal



Cod: **30811**  
cm: L1,5xH4,5  
pz: 3Blister  
mat: MT



Cod: **30812**  
cm: L2,3xH8,5  
pz: 3Blister  
mat: MT

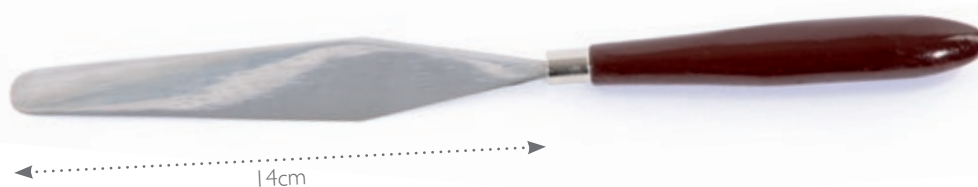

Cod: **30813**  
cm: L2,5xH14  
pz: 3Blister  
mat: MT



# PRODOTTI PER L'HOBBISTICA

Hobby products  
Produits pour le loisir  
Produkte für Hobbybäcker

Productos para hobbies  
Produtos para hobbies

## PENNELLI

Brushes | Pinceaux | Pinsel | Pinceles | Pincéis



### SETOLE IN NYLON

Nylon bristles  
poils en nylon  
Nylonborsten  
Cerdas de nylon  
Cerdas em nylon

Cod: **30848P**

●●● A

■ ■ ■ 6

cm: H17,5/21,5

pz: 1Blister(6pz)

## PENNELLI PER MODELLARE

Modelling brushes | Pinceaux pour le modelage | Modellierpinsel | Pinceles para moldear | Pincéis para modelar

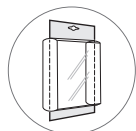

Cod: **30850P**

●●● A

■ ■ ■ 5

cm: H19,5

pz: 1Blister(5pz)

MEDI  
Medium  
Moyens  
Mittelgroß  
Medios  
Médios

### PUNTE IN SILICONE

Silicone tips  
Pointes en silicone  
Silikonspitzen  
Puntas de silicona  
Pontas em silicone

PICCOLI  
Small  
Petits  
Klein  
Pequeños  
Pequenos

Cod: **30851P**

●●● A

■ ■ ■ 5

cm: H14,5/15,5

pz: 1Blister(5pz)





## BISTURI

Scapel | Bistouris | Skalpell | Bisturí | Bisturis

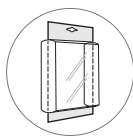

Cod: **30361**  
cm: H14,5  
pz: 1Blister(3pz)  
mat: MT

## LAME RICAMBIABILI

Replaceable blades | Lames changeables | Austauschbare  
Klingen | Cuchillas recambiables | Lâminas intercambiáveis

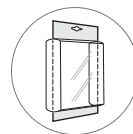

Cod: **30849**  
cm: L1xH2,5  
pz: 10Blister(5pz)  
mat: MT

## PINZE

Tweezers | Pincas | Zangen | Pinzas | Pinças

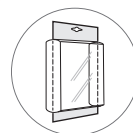

Cod: **30363**  
cm: H11/12  
pz: 1Blister(4pz)  
mat: MT

## PUNTERUOLO

Pick | Pointeau | Körner | Punzón | Furador

Da utilizzare per scrivere e per riportare schemi e disegni su soggetti da decorare

Use for writing and drawing diagrams and designs on the item to be decorated

À utiliser pour écrire et pour reproduire des schémas et des dessins sur sujets à décorer

Zum Schreiben und zum Übertragen von Schemata und Zeichnungen auf Dekor-Figuren

Utilizar para escribir y para reproducir esquemas y dibujos sobre sujetos a decorar

Utilizar para escrever e reproduzir esquemas e desenhos sobre os artigos que se irá decorar

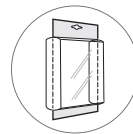
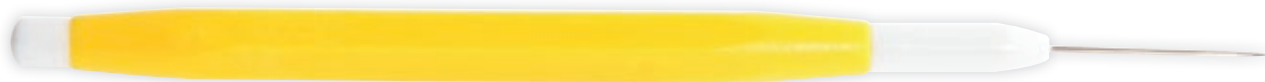

Cod: **30866P**  
cm: H14,5  
pz: 1Blister



# PRODOTTI PER L'HOBBISTICA

Hobby products  
Produits pour le loisir  
Produkte für Hobbybäcker

Productos para hobbies  
Produtos para hobbies

## SFERE MODELLA FIORI

Sphere-shaped flower modelling tool | Sphères pour modeler les fleurs | Kugel, um Blumen zu modellieren | Bolillos metálicos para moldear flores | Esferas metálicas para modelar flores

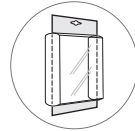

Cod: **31236**

● ● ● A

■ ■ ■ 4

cm: H13,5

pz: 1 Blister(4pz)

mat: MT

## PROFESSIONAL CLAY GUN

Professional clay gun | Clay gun professionnelle | Professioneller "Clay Gun"  
Clay gun professional | Clay gun professionnel

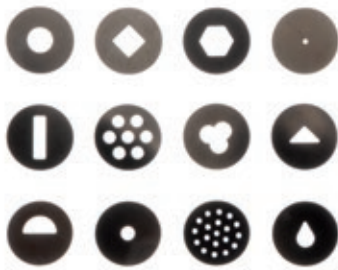

Cod: **31237**

cm: H16,5

pz: 1 Blister(21pz)

mat: MT

## TAPPETINO MODELLA FIORI

Mat for modelling flowers | Peiti tapis pour modeler les fleurs | Matte, um Blumen zu modellieren  
Tapete para moldear flores | Tapete para modelar flores

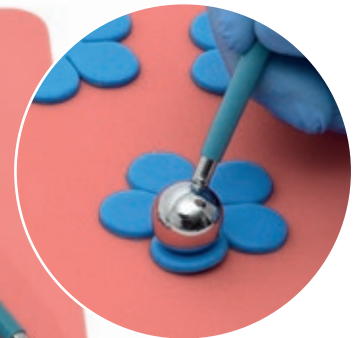

Cod: **30221**

cm: L24xH1,5xP18,5

pz: 1

mat: SP

# LA NUOVA STAMPANTE ALIMENTARE

The new food grade printer  
La nouvelle imprimante alimentaire  
Der neue Lebensmitteldrucker

# DECOJET REVOLUTION

## Basta cartucce... Benvenuti serbatoi:

un flusso diretto di inchiostro da serbatoio a testina che supera la tecnologia dei chip e i limiti dell'elettronica

## No more cartridges... Welcome tanks:

a direct flow of ink from the tank to the head - that exceeds the chips technology and the limits of electronics

## Plus de cartouches... Bienvenu aux

**réservoirs:** un flux direct d'encre du réservoir à la tête d'impression qui dépasse la technologie des puces et les limites électroniques

## Verabschieden Sie sich von Patronen... Und

**sagen Sie Hallo zu Tanks:** ein direkter Tintenfluss von dem Tank zu dem Druckkopf - übertrifft die Chips-Technologie und die Grenzen von Elektronik

## Basta de cartuchos... Bienvenidos tanques:

un flujo directo de tinta del tanque al cabezal - que supera la tecnología de los chip y los límites de la electrónica

## Stop aos tinteiros... Bem-vinda aos

**depósitos:** Um fluxo directo de tinta desde os depósitos até a cabeça - que supera a tecnologia dos chip e os limites electrónicos



Cod: 30580

cm: L45xH38xP23

pz: 1

DECORARE IN  
LABORATORIO  
Decorating in the lab

La certificazione Modecor rende una semplice stampante un macchinario alimentare, conforme alle **nuove stringenti normative europee**

Modecor certification transforms a simple printer into a foodgrade machine, in **conformity with the new strict European regulations**

La certification Modecor transforme une imprimante simple en machine alimentaire, conforme aux **nouvelles normes européennes strictes**

Die Modecor Zertifizierung wandelt einen normalen Drucker in ein **neuen stringenden europäischen Gesetzte entsprechendes Lebensmittelgerät um**

La certificación Modecor, hace que una simple impresora se transforme en una máquina alimentaria, en conformidad a **las nuevas y estrictas normas europeas**

A certificação Modecor, faz que uma simples impressora se transforme em uma máquina alimentícia, **conforme as novas e estritas normas europeias**





# CARATTERISTICHE TECNICHE

Technical characteristics  
Caractéristiques techniques  
Technische Details

Características técnicas  
Características técnicas

DECOJET  
REVOLUTION



- Multifunzione: copia, scan, stampa da PC, adatta pagina, Zoom, Mirroring, Clone e Poster (Solo da PC)
- Ambiente di lavoro: Windows Xp/Vista/7/8
- Velocità di stampa: qualità alta: 2'00"
- Inclusi nella confezione: driver di installazione (CD), Decojet creator (software di gestione immagini), Getting started (manuale di istruzioni per l'uso)
- Certificati: fascicolo di certificazione, Direttive UE per la macchine alimentari
- Warning: consigli d'uso per utilizzare la macchina al massimo del suo potenziale
- Nuovo sito internet dei servizi Modacor: accesso semplificato alle info sulla Decojet Revolution, video d'installazione e risoluzione
- Garanzia: 1 anno (in caso di mancata risoluzione problemi tramite assistenza Modacor, sostituzione simultanea con una stampante nuova)

- Multifunction: copies, scans, prints from PC, fit to page, Zoom, Mirroring, Clone and Poster (only from PC)
- Operating systems: Windows XP/Vista/7/8
- Printing time: high quality: 2'00"
- Included in box: installation driver (CD), Decojet creator (software for image management), Getting started (instruction manual)
- Certificates: certifications booklet, EU Food Machinery Directives
- Warning: tips for using your printer to its full potential
- New Modacor Service website: simple access to info about the Decojet Revolution, video for installation, settings and problem solving
- Warranty: 1 year (new printer "SWAP" service if Modacor Customer Service cannot resolve the problem)

- Multifonction: copie, scanner, impression depuis le PC, Largeur page, Zoom, Miroir, Clonage et Poster (seulement depuis le PC)
- Système d'exploitation : Windows XP/ Vista/7/8
- Délai d'impression: haute qualité: 2'00"
- Comprises dans l'emballage: pilote d'installation (CD), Decojet creator (logiciel pour la gestion des images), Mise en route (Mode d'emploi)
- Certificats: dossier de certification, Directives UE relative aux machines alimentaires
- Avertissement: conseils pour utiliser votre imprimante à son plein potentiel
- Nouveau site internet des services Modacor : accès simplifié aux info sur la Decojet Revolution, vidéo d'installation et résolution
- Garantie: 1 an (si les problèmes ne sont pas résolus par le SAV Modacor, remplacement immédiat avec une nouvelle imprimante)

- Multifunktion: Kopie, Scan, Ausdruck vom PC, format angleichen, Zoom, Mirroring, Klon und Poster (nur vom PC)
- Betriebssysteme: Windows XP/Vista/ Win7/8
- Druck-Zeit: Hohe Qualität: 2'00"
- In der Verpackung enthalten: Installationsstreiber (CD), Decojet creator (Software für die Verarbeitung von Bildern), Erste Schritte (Gebrauchsanleitung)
- Zertifikate: Zertifikat, EU-Richtlinien für Nahrungsmittelmachines
- Warnung: Tipps zur Verwendung des Druckers zu seinem vollen Potential
- Neue Website zu den Modacor-Leistungen: einfacher Zugang zu den Infos über Decojet Revolution, video mit Einstellung und Problemlösung
- 1 Jahr Garantie (Falls es zu keiner Problemlösung durch den Modacor Kundendienst kommt, gewähren wir einen gleichzeitigen Ersatz durch einen neuen Drucker)

- Multifunción: copia, scan, impresión desde PC, Ajusta a la página, Zoom, Mirroring, Clone, Poster (Sólo desde PC)
- Sistemas operativos: Windows XP/Vista/7/8
- Tiempo de impresión: calidad alta: 2'00"
- Incluidos en el paquete: controlador de instalación (CD), Decojet creator (software para la gestión de las imágenes), Getting started (manual de instrucciones para el uso)
- Certificados: expediente de certificación, Directivas UE para las máquinas alimentarias
- Advertencia: Instrucciones para el uso de la impresora en todo su potencial
- Nuevo sitio Internet de los servicios Modacor: acceso simplificado a la información sobre la Decojet Revolution, video de instalación y resolución
- Garantía: 1 año (en caso de falta de solución de problemas a través de la asistencia Modacor, sustitución simultánea con una impresora nueva)

- Multifuncional: cópia, digitaliza, imprime do PC, adaptação à página, Zoom, Mirroring, Clone e Poster (Somente do PC)
- Sistema operativo: Windows XP/Vista/7/8
- Tempo de impressão: qualidade alta: 2'00"
- Incluídos na embalagem: driver de instalação (CD), Decojet creator (software para a gestão de imagens), Getting started (manual do utilizador)
- Certificados: documentação de certificação, Diretivas UE para equipamentos alimentares
- Aviso: sugestões para utilizar a impressora para o seu pleno potencial
- Novo sítio Internet dos serviços Modacor: acesso simplificado às informações sobre Decojet Revolution, video de instalação e resolução
- Garantia: 1 ano (em caso de falta de resolução de problemas através da assistência Modacor, substituição simultânea com uma impressora nova)

Assistenza diretta da parte del personale Modacor per tutte le stampanti Modacor

Direct customer assistance by Modacor personnel for all Modacor printers

Service assistance direct du personnel Modacor pour toutes les imprimantes Modacor

Direkte Betreuung durch das Modacor Personal für alle Modacor Drucker

Asistencia directa por parte del personal de Modacor para todas las impresoras de marca Modacor

Assistência direta por parte da equipa Modacor para todas as impressoras da marca Modacor



e-mail: service@decojet.it



e-mail: service@decojet.it



e-mail: service@decojet.it

# STARTER KIT SERBATOI

Starter Kit tanks  
Starter Kit Réservoirs  
Starter Kit Tanks

Starter Kit Tanques  
Starter Kit Depositos

**DECOJET**  
REVOLUTION

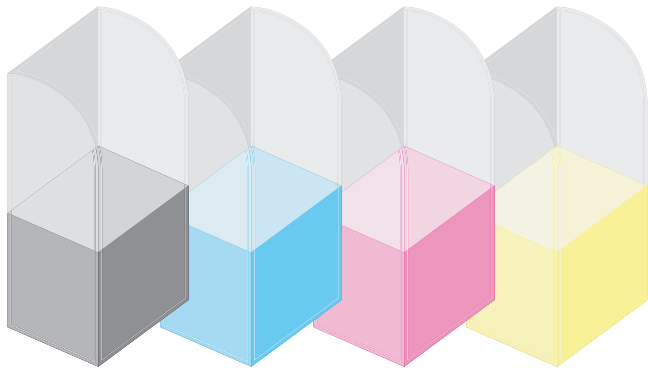

1 KIT =  
4 SERBATOI REGULR  
4 small tanks  
4 petits réservoirs  
4 kleine Tanks  
4 tanques pequeños  
4 depósitos pequenos



Cod: 30589  
pz: 1  
Gluten free



## SERBATOI

Tank            Tanques  
Réservoir    Deposito  
Tank

L'inchiostro contenuto in un Serbatoio è **il doppio (2x) o addirittura il quadruplo (4x) di una cartuccia standard** (per Decojet A4). Ciò significa sostituzioni meno frequenti e quindi ridotta manutenzione!

The ink contained in a tank **is double the amount (2x) and even up to four times (4x) more than a standard cartridge** (for Decojet A4). This means less frequent replacement and therefore less maintenance!

L'encre contenu dans un réservoir est **le double (2x) ou même le quadruple (4x) d'une cartouche standard** (pour Decojet A4). Cela signifie moins de remplacements et donc moins d'entretien!

Der Fassungsvermögen von dem Tank **ist zweimal (2x - bei dem kleinen Tank) oder viermal (4x - bei dem großen Tank) mehr im Vergleich mit traditionellen Patronen** (für Decojet A4). Ökonomische Ersparnis der Tintermenge: dies bedeutet weniger Austauschen und deswegen eine minimale Wartung!

La tinta contenida en un tanque, es **el doble (2x) o cuádruple (4x) de un cartucho standard** (para Decojet A4). Esto significa reemplazos menos frecuentes y, por lo tanto, poco mantenimiento!





A tinta que contem o depósito, é **o dobro (2x) ou o quadruplo (4x) de um tinteiro standard** (para Decojet A4). Isto significa substituição com menos frequência e, pelo tanto, pouca manutenção!

DECORARE IN  
LABORATORIO  
Decorating in the lab

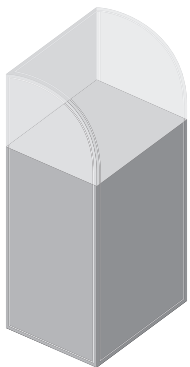
## SERBATOIO MAXI (4X)

Large tank (4x) | Réservoir Grand (4x) | Grosser Tank (4x)  
Tanque grande (4x) | Deposito grande (4x)



 Cod: 30581  
 Cod: 30582  
 Cod: 30583  
 Cod: 30584

pz: 1  
Gluten free

## SERBATOIO REGULAR (2X)

Small tank (2x) | Réservoir Petit (2x) | Kleiner Tank (2x)  
Tanque pequeño (2x) | Deposito pequeno (2x)

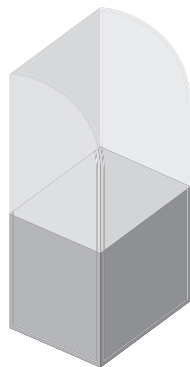

 Cod: 30585  
 Cod: 30586  
 Cod: 30587  
 Cod: 30588

pz: 1  
Gluten free

Serbatoi che durano più a lungo, significa: **meno sostituzioni, meno spreco di inchiostro durante le sostituzioni, e meno spreco di tempo.** Inoltre i Serbatoi hanno un prezzo più basso per ml

Longer lasting tanks mean: **less ink waste during cartridge change, and less wasting time.** In addition, tanks have a lower cost per ml

Réservoirs qui durent plus longtemps: **cela signifie moins de remplacements, moins de gaspillage d'encre pendant les remplacements et moins de perte de temps.** En plus les réservoirs ont un prix inférieur par ml

Durch den vergrößerten Fassungsvermögen **ist der Austausch der Tanks weniger häufig, das heißt weniger Tinten- und Zeitverschwendung.** Dazu ist der Preis pro ml mit den Tanken billiger

Tanques que duran más tiempo, significa: **menos reemplazos, menor desperdicio de tinta durante los reemplazos, y menor pérdida de tiempo.** Además, los tanques, tienen un precio más bajo por ml

Depósitos que duram mais tempo, significa **menos substituições. Menos desperdício de tinta durante a substituição, e menos perda de tempo.** E os depósitos tem um preço por ml inferior



# SWEET STICKERS

FOGLI PER STAMPA ALIMENTARE FORMATO A4  
A4 size edible printing paper  
Feuilles pour impression alimentaire format A4

Blätter für Lebensmitteldruck Format A4  
Hojas para impresión alimentaria formato A4  
Folhas para impressão alimentar formato A4



PRETAGLIATO  
pre-cut  
0,45  
mm

Ø20 cm

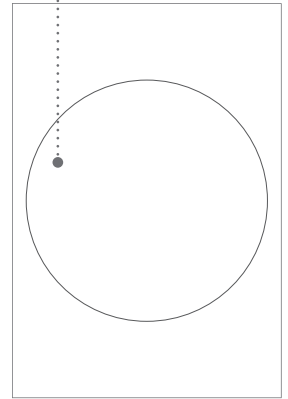

Cod: **10516**  
cm: A4(L21xH29,7)  
pz: 25  
mat: ZU

L6 cm

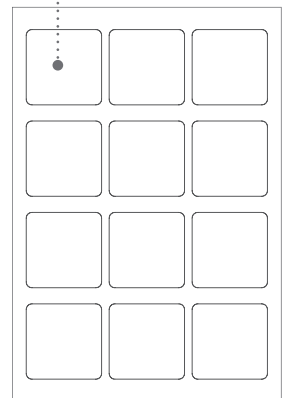

Cod: **10517**

Ø6 cm

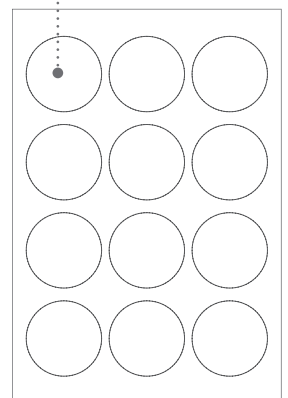

Cod: **10518**





DECORARE IN  
LABORATORIO  
Decorating in the lab

Software Decojet Creator aggiornato con le nuove forme | Decojet Creator Software updated with new shapes | Logiciel Decojet Creator mis à jour avec les nouvelles formes | Software Decojet Creator aktualisiert mit den neuen Formen Software | Decojet Creator actualizado con las nuevas formas | Software Decojet Creator atualizado com as novas formas

ISTRUZIONI  
HOW  
TO USE



L3,8 cm

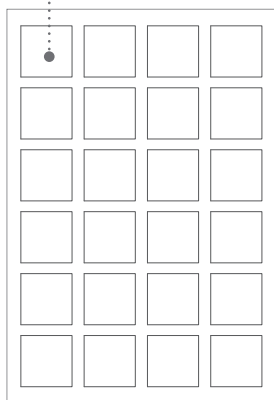

Cod: **10514**  
cm: A4(L21xH29,7)  
pz: 25  
mat: ZU

PRETAGLIATO  
pre-cut

0,45  
mm

Ø3 cm

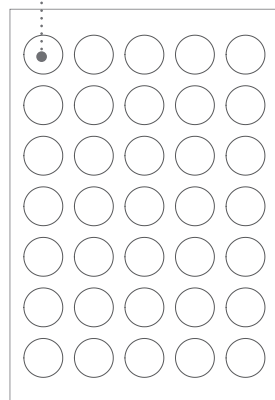

Cod: **10515**

**Decor  
Aid**



LACCA ALIMENTARE  
SPRAY

Food lacquer spray  
Laque alimentaire en spray  
Lebensmittel-Lackspray  
Laca alimentaria spray  
Laca em spray para alimentos

Cod: **24400**  
ml: 400  
pz: 1  
Gluten free





# SUPPORTI PER STAMPANTI ALIMENTARI

Edible media  
Supports pour imprimantes alimentaires  
Esspapier für Lebensmitteldrucker

Soportes para impresora alimentaria  
Suportes para as impressoras alimentares

L'elevata qualità dei supporti Moddecor permette la **massima qualità di stampa con il minimo impiego di inchiostro**

The high quality of Moddecor edible media allows **maximum printing quality with minimal ink use**

La haute qualité des supports Moddecor permet la **meilleure qualité d'impression en utilisant le minimum d'encre**

Die hohe Qualität der Moddecor Esspapiere erlaubt die **maximale Druck-Qualität mit dem minimalen Tintenverbrauch**

La alta calidad de los consumibles Moddecor; permite la **máxima calidad de impresión, con la mínima cantidad de tinta**

A alta qualidade dos consumíveis Moddecor; permite a **maxima qualidade de impressão, com a minima quantidade de tinta**



COD	FOGLI   Sheets   Feuilles   Folien   Hojas   Folhas	FORMATO   Size Format   Format Formato   Formato	SPESSORE   Thickness Épaisseur   Dicke Espesor   Espessura	PZ	MAT	GLUTEN FREE
10513	PASTA DI ZUCCHERO   Sugar paste   Pâte à sucre Zuckermasse   Pasta de azúcar   Pasta de açúcar	A4 L21xH29,7 cm	0,54 mm	50	ZU	
10507	PASTA DI ZUCCHERO   Sugar paste   Pâte à sucre Zuckermasse   Pasta de azúcar   Pasta de açúcar	A3 L42xH29,7 cm	0,54 mm	30	ZU	
10503	PER STAMPA ALIMENTARE   For edible printing   Pour impression alimentaire   Für Lebensmitteldruck   Para impresión alimentaria   Para impressão alimentar	A4 L21xH29,7 cm	0,45 mm	50	ZU	



## LACCA ALIMENTARE SPRAY PER 10503

Food lacquer spray for 10503 | Laque alimentaire en spray pour 10503  
Lebensmittel-Lackspray für 10503 | Laca alimentaria spray para 10503  
Laca em spray para alimentos para 10503

Per un miglior isolamento, si consiglia di spruzzare sul retro della stampa (10503) il Decor Aid - Lacca Alimentare Spray prima di posizionarla sul dolce

Pour une meilleure isolation il est conseillé de vaporiser le Decor Aid - Laque alimentaire spray - sur le dos du support (10503) imprimé avant de le positionner sur le gâteau

Para un mejor aislamiento de la impresión (10503), se sugiere de rociarla en la parte posterior, con el Decor Aid - Laca Alimentaria Spray - antes de colocar la misma en la tarta

Cod: **24400**  
ml: 400  
pz: 1  
Gluten free

For better isolation, we recommended to spray on print backside (10503) the Decor Aid - Food Lacquer Spray, before positioning it on the sweet

Um den Druck vor Feuchtigkeit zu schützen (10503), empfehlen wir die Rückseite der Folie, vor diese auf die Torte gelegt wird, mit Decor Aid- Lebensmittellack zu besprühen

Para uma melhor isolamento (10503), aconselhamos pulverisar na parte superior, com o DecorAid - laca alimentar em spray - antes de colocar sobre o bolo





COD	FOGLI   Sheets   Feuilles   Folien   Hojas   Folhas	FORMATO   Size Format   Format Formato   Formato	SPESSORE   Thickness Épaisseur   Dicke Espesor   Espessura	PZ	MAT	GLUTEN FREE
13501	CIALDA   Wafer   Azyme Oblatenpapier   Oblea   Obreia	A4 L21xH29,7 cm	0,55 mm	100	WF	✓
13504	CIALDA   Wafer   Azyme Oblatenpapier   Oblea   Obreia	A3 L42xH29,7 cm	0,55 mm	50	WF	✓
13505	CIALDA LISCISSIMA   Extra smooth wafer   Azyme très lisse Extra glatte Oblate   Oblea extra-lisa   Obreia extralisa	A4 L21xH29,7 cm	0,60 mm	100	WF	
13503	CIALDA ULTRA-FINE   Extra thin wafer   Azyme ultra-fine Oblaten extra dünn   Oblea ultra-fina   Obreia ultra-fina <del>DECOJET REVOLUTION</del>	A4 L21xH29,7 cm	0,30 mm	100	WF	✓
10504	CHOCOTRANSFER	A4 L21xH29,7 cm	-	30	-	✓



Chocotransfer per stampanti alimentari: foglio su cui stampare immagini da trasferire sul cioccolato

Chocotransfer for edible printing: sheet for printing edible pictures on chocolate

Chocotransfert pour imprimantes alimentaires: feuille sur laquelle imprimer les images à transférer sur le chocolat

Schokofolie für Lebensmitteldruck: Abziehfolie für essbare Bilder auf Schokolade

Chocotransfer para impresoras alimentarias: hoja sobre la cual imprimir imágenes para transferir en chocolate

Chocotransfer para impresoras alimentares: folha de impressão de imagens para transferência em chocolate

## RISERVA BIANCA SPRAY PER CHOCOTRANSFER

White base spray for Chocotransfer | Base blanche spray pour Chocotransfer  
Spray- weißer Hintergrund für Chocotransfer | Base blanca spray para Chocotransfer  
Spray base branca para Chocotransfer



Spray base bianca da applicare su fogli di Chocotransfer per trasferire immagini e foto su cioccolato fondente

White-base to be sprayed on Chocotransfer: it allows you to transfer images and pictures onto dark chocolate

Spray à base blanche, à appliquer sur feuilles de Chocotransfert pour transférer les images et photos sur chocolat noir

Spray für weißen Untergrund auf Schokofolie, für Bilder und Fotos auf Zartbitterschokolade

Spray de base blanca para rociar sobre hojas de Chocotransfer; para transferir imágenes y fotos sobre chocolate negro

Spray de base branca para aplicar sobre folhas de Chocotransfer; para transferir imagens e fotografias sobre o chocolate preto

Cod: 24557  
ml: 400  
pz: 1  
Gluten free





# GELATINA ALIMENTARE

Edible gelatine  
Gélatine alimentaire  
Lebensmittel Gelatine

Gelatina alimentaria  
Geleia alimentar

## ModecorGel



Cod: **24190**  
Kg: 1  
pz: 4  
mat: GE  
Gluten free



## Decorgel

EFFETTO TRASPARENTE

Transparent effect | Effet transparent | Transparent-Effekt | Efecto transparente | Efeito transparente



GIALLO  
Cod: **23207E**  
Kg: 1  
pz: 1  
mat: GE  
Gluten free



ROSSO  
Cod: **23207D**



ROSA  
Cod: **23207B**



BLU  
Cod: **23207K**



VERDE  
Cod: **23207L**

## Decorgel METAL

EFFETTO METAL

Metal effect | Effet métal | Metall-Effekt Efecto metal | Efeito metálico



ORO  
Cod: **23208I**  
Kg: 1  
pz: 1  
mat: GE  
Gluten free



ARGENTO  
Cod: **23208H**



Consistenza ideale  
per decori e scritte a  
cometto

Ideal consistency for  
writing and  
decorating

Consistance idéale  
pour décorations et  
inscriptions avec une  
poche à douille

Ideale Konsistenz zum  
Verzieren und Schrei-  
ben mit Spritzbeutel

Consistencia ideal  
para decoraciones y  
escrituras con  
cucurucho

Consistência ideal  
para decorações e  
escritas com saco de  
confeitar

# CARTUCCE ALIMENTARI MONOUSO

Disposable cartridges for edible printing  
Cartouches alimentaires jetables  
Einweg-Lebensmittelpatronen

Cartuchos alimentarios desechables  
Tinteiros alimentares descartáveis



## CARTUCCE A3

A3 Cartridges | Cartouches A3 | Patronen A3  
Cartuchos A3 | Tinteiros A3

- Cod: **30431** Nero
- Cod: **30432** Ciano
- Cod: **30433** Magenta
- Cod: **30434** Giallo

pz: |  
Gluten free



## CARTUCCE A4

A4 Cartridges | Cartouches A4 | Patronen A4  
Cartuchos A4 | Tinteiros A4

- Cod: **30436** Nero
- Cod: **30437** Ciano
- Cod: **30438** Magenta
- Cod: **30439** Giallo

pz: |  
Gluten free



## CARTUCCE DEDICATE A DECOPLTTY 30153

Cartridges for the 30153 Decoplotty | Cartouches pour le Decoplotty 30153 | Patronen für Decoplotty 30153 | Cartuchos para Decoplotty 30153 | Tinteiros para Decoplotty 30153



Cod: **30154**  
●  
pz: |



Cod: **30155**  
● ● ●  
pz: |

*Cartucce disponibili fino a dicembre 2016 | Cartridges available until december 2016 | Cartouches disponibles jusqu'en décembre 2016 | Patronen erhältlich bis Dezember 2016 | Cartuchos disponibles hasta diciembre 2016 | Tinteiros disponíveis até dezembro 2016*

## TESTINA DI STAMPA

Print head | Tête d'impression | Druckkopf  
Cabezal de impresión | Cabeça de impressão



Cod: **30189**  
pz: |

Compatible con stampanti Decojet C1 e Decojet C2

Compatible with Decojet C1 and Decojet C2 printer

Compatible avec imprimantes Decojet C1 et Decojet C2

Kompatibel mit Decojet C1 und Decojet C2 Drucker

Compatible con impresoras Decojet C1 y Decojet C2

Compatível com impressoras Decojet C1 e Decojet C2



# CARTUCCE ALIMENTARI MONOUSO

Disposable cartridges for edible printing  
Cartouches alimentaires jetables  
Einweg-Lebensmittelpatronen

Cartuchos alimentarios desechables  
Tinteiros alimentares descartáveis



## CARTUCCE AZO

AZO cartridges | Cartouches azoïques | AZO Patronen  
Cartuchos azoicos | Tinteiros azóicos

- Cod: **30231** Nero grande
- Cod: **30232** Nero
- Cod: **30233** Ciano
- Cod: **30234** Magenta
- Cod: **30235** Giallo

pz: 1  
Gluten free



## CARTUCCE AZO

AZO cartridges | Cartouches azoïques | AZO Patronen  
Cartuchos azoicos | Tinteiros azóicos

- Cod: **30171** Nero grande
- Cod: **30172** Nero
- Cod: **30173** Ciano
- Cod: **30174** Magenta
- Cod: **30175** Giallo

pz: 1  
Gluten free

## CARTUCCE AZO FREE

Azo free cartridges | Cartouches non azoïques | Azo freie  
Patronen | Cartuchos no azoicos | Tinteiros não azóicos

- Cod: **30236** Nero grande
- Cod: **30237** Nero
- Cod: **30238** Ciano
- Cod: **30239** Magenta
- Cod: **30240** Giallo

pz: 1  
Gluten free

## KIT PULIZIA (5 CARTUCCE)

Cleaning kit (5 cartridges) | Kit nettoyage (5 cartouches)  
Reinigungskit (5 Patronen) | Kit de limpieza (5 cartuchos)  
Kit de limpeza (5 tinteiros)

Cod: **30241**  
pz: 1  
Gluten free



## KIT PULIZIA (5 CARTUCCE)

Cleaning kit (5 cartridges) | Kit nettoyage (5 cartouches)  
Reinigungskit (5 Patronen) | Kit de limpieza (5 cartuchos)  
Kit de limpeza (5 tinteiros)

Cod: **30181**  
pz: 1  
Gluten free

Le multifunzioni Decojet C1 e C2 sono garantite per l'utilizzo alimentare. Non è possibile utilizzare cartucce NON ALIMENTARI

The Decojet C1 and Decojet C2 are guaranteed for edible printing only. It is not possible to use printing cartridges containing NON EDIBLE INK

Les imprimantes multifonction Decojet C1 et C2 sont garanties pour une utilisation alimentaire. Il n'est pas possible d'utiliser des cartouches NON ALIMENTAIRES

Der Decojet C1 und Decojet C2 sind nur für den Gebrauch mit Lebensmitteln garantiert. Es ist nicht möglich, andere Patronen zu verwenden

Las multifunciones Decojet C1 y C2, están garantizadas para uso alimentario. NO admiten cartuchos NO alimentarios

As multifunções Decojet C1 e C2 estão garantidas para uso alimentar. Não admite tinteiros NÃO ALIMENTARES

# Magic Spray



## DecorAid

Per fissare le stampe, esaltarne la qualità e garantirne la conservazione

To fix prints, enhance the quality and ensure their preservation

Pour fixer les impressions, en exalter la qualité et en garantir la conservation

Zur Fixierung des Drucks, zur Hervorhebung seiner Qualität und zur Verlängerung der Haltbarkeit

Para fijar las impresiones, resaltar la calidad y asegurar la conservación

Para fixar as impressões, exaltar a sua qualidade e garantir a sua conservação

Cod: 24679  
ml: 400  
pz: 1

DECORARE IN  
LABORATORIO  
Decorating in the lab

# GUANTI MONOUSO IN NITRILE

Disposable nitrile gloves  
Gants mono-usage en nitrile  
Nitril-Einweghandschuhe

Guantes desechables de nitrilo  
Luvas descartáveis de nitrilo

ANALLERGICI  
Hypoallergenic  
Anti-allergique  
Antiallergisch  
Analérgicos  
Anti-alérgico

100%

LIBERI DA POLVERE  
Powder-free  
Sans poussière  
Pulverfrei  
Libres de polvo  
Livres de pó



77,5cm

8/8,5cm

Cod: 30214  
cm: M  
pz: 100

Cod: 30215  
cm: L  
pz: 100